

# CytoTherm

110 Sewell Ave. Trenton NJ 08610 USA  
Tel 800 747-9699 or 609 396-1456 Fax 609 396-9395  
Email serve@cytotherm.com Web www.cytotherm.com

## CytoTherm-4T

PLASMA THAWING  
ROCKING WATER BATH  
with TURBO ACTION

Model **CT-4T**

Owners Manual  
Version 408 and higher.  
Corral mounts on shelf.

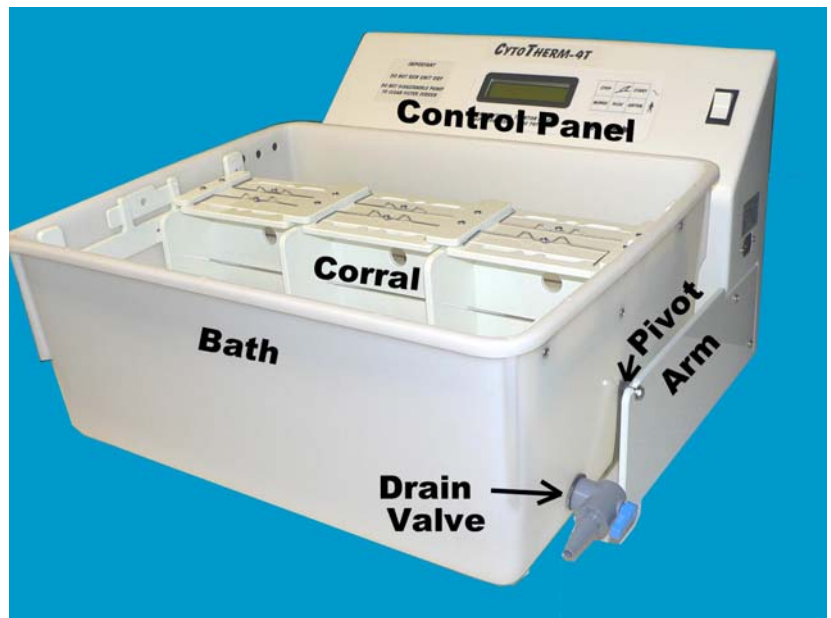

### WARRANTY

Each CytoTherm product is produced under rigid quality control standards. This unit is fully warranted for a period of one year from the date of purchase. Call 609 396-1456 or 800 747-9699 for help. If necessary send unit to:  
CytoTherm 110 Sewell Ave. Trenton, NJ USA Tel 609 396-1456 Fax 609 396-9395

Please mail in your warranty card.

Please record the following: Serial No. \_\_\_\_\_ Date of Purchase \_\_\_\_\_

### TABLE OF CONTENTS

\\DrawRec\Draw\Instruct\CT4TinsJ.doc 31 Oct. 07

1	Specifications	6	Troubleshooting
2	Description	7	Maintenance
2	Setting-up	8	Parts List
4	Operation	8	Technician Functions
4	Leaky Plasma Bag	9	Safety Features
4	Cleaning the Bath	9	Accessories
5	Modes	10	Wiring Diagram

### SPECIFICATIONS

Thawing temperature adjustable 25°C to 40° C. Preset to 37.0°C. Overtemp Alarm 1.0°C over thawing temperature. 45°C safety thermostat. Accuracy 0.1°C. Easy to do, digital temperature calibration. Power 770 Watt, Available in 120 Volt or 230 Volts, 50 or 60 Hz. (must be grounded). Will thaw 300 ml. & 450 ml. plasma bags.

## **DESCRIPTION**

The CytoTherm-4T (CT-4T) is a laboratory instrument that consists of a recirculating water temperature bath that uses a rocking action to generate bursts of flow to massage the plasma. This massaging action speeds up the thawing time.

The CT-4T comes with one CORRAL that will thaw 1 to 6 plasma bags at a time. A second CORRAL will let you thaw 6 more plasma bags for a total of up to 12 units at a time. The operator never comes in contact with the water in the bath when handling the plasma bags. The CORRAL keeps the entry ports of flat-frozen units out of the water so an overwrap bag is not necessary. Folded frozen plasma units require an overwrap bag to protect the entry ports. Both type of freeze methods can be thawed together.

A large digital display indicates the temperature and counts down the thawing time. The CT-4T comes with a clear evaporation lid.

## **SETTING-UP**

The unit comes packed in 1 box. Make sure you have received the following:

..... Control Panel	..... Bath
..... Corral with 6 Bag Clamps	..... 2 Arms
..... Drain Tubing	..... Evaporation Lid
..... Power Cord	.....Instruction Book
..... Overwrap bags	.....Video or DVD
.....Algaecide. USA only	

Screw the ARMS to the side of the CONTROL SECTION. The notched side of the ARMS face up.

Place the BATH in front of the CONTROL SECTION so that the chassis on the BATH is next to the indented portion of the CONTROL SECTION.

Connect the umbilical cord of the CONTROL SECTION to the plug receptacle on the back of the BATH section.

**\* \* THE POWER SWITCH MUST BE OFF  
WHEN CONNECTING OR DISCONNECTING THIS CONNECTION \* \***

Lift the BATH and position it so that the pivots on the side of the BATH slip into the notches on the ARMS.

Make sure the power switch is OFF. Connect the power cord to a properly grounded electrical outlet.

Mount the CORRAL inside the BATH. Push The SLIDERS on both sides of the BATH towards the front of the BATH. In this SLIDER position the CORRAL can be placed on the BACK SHELF. Mount the first CORRAL towards the back of the BATH. The cutout of the CORRAL should be on the right side. Push the SLIDER to its middle position, this will hold the CORRAL in place.

Second CORRAL (optional accessory). If you are mounting a second CORRAL to thaw up to 12 plasma bags at a time, push the SLIDERS towards the back of the unit and mount the second CORRAL on the front SHELF. The second CORRAL mounts like the first CORRAL. Move the SLIDER to the center to hold both CORRALs.

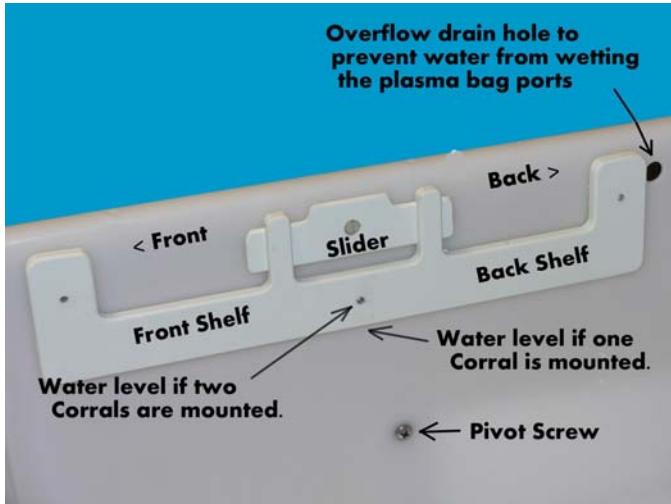

Make sure that the DRAIN Valve is closed (horizontal). Fill the BATH with tap water to the bottom of the SHELF if you have one CORRAL mounted and to the screw of the shelf if you have 2 CORRALs mounted. If your tap water contains a lot of lime, use distilled or de-ionized water, add a pinch (0.01gr.) of salt to make the water conductive so that the level sensors will work. Do NOT use saline solution. . Add Algaecide Part #ALG240 (1.0 ml. per 4 liter of water. Available USA only) to the water. Any other bath clearing agent can also be used.

Make sure the power switch is OFF. Plug the power cord into a properly grounded electrical outlet. Turn the power switch ON. The pump will start pumping the water and the display will indicate the temperature. The unit will heat up to 37.0°C. The display will show “HEAT ON” when the unit is heating.

Use the LID over the bath to prevent evaporation and help keep the water cleaner. DO NOT USE THE LID WHEN THAWING, as water condensate from the lid may drip onto the plasma bag ports.

Open the LID by lifting from the front. Hold the front of the LID up to let the condensate flow back into the Bath, then lift up the LID and place it aside.



## **OPERATION**

Wait for the water to heat up to 37.0°C.

For your protection, use gloves when working with any blood products.

Flat-frozen plasma units can be thawed without an overwrap bag. Hold a bag of flat-frozen plasma (bare or overwrapped) with the ports up and the label on the plasma unit away from the center of the CORRAL. Slip the CLAMP (plastic bar with a stainless spring attached) over the top of the bag and line up the 3 grooves in the CLAMP with the ports of the plasma bag.

Place the bottom of the plasma bag into the water, between the stainless rods of the CORRAL. Pull the stainless spring of the CLAMP over the screw head in the CORRAL. The spring should pull the plastic bar and plasma bag snugly against the corral. The spring tension can be adjusted by bending the stainless steel spring. If the stainless steel spring breaks, the clamp must be replaced (Part # C4T-CLM).

Folded frozen plasma must be overwrapped. Load it the same way. The CLAMP will hold the plasma unit by the overwrap bag.

Push START to begin thawing for the programmed time. The Rocking Motor will turn on. The water in the bath will be forced to flow through the large holes in the dividing plate of the CORRAL and will massage the plasma bags. Use PLUS or MINUS to increase or decrease the thawing time. When the time is finished, the buzzer will call the operator back.

The STOP switch ends the thawing. If more thawing time is needed, hold PLUS while pushing START and the unit will thaw for another 3 minutes.

## **LEAKY PLASMA BAG**

If a Plasma bag leaks, turn the unit off and discard the leaking bag. The remaining bags are not contaminated, because the ports are always kept out of the water. Dry off the plasma bags with paper towels and wipe with a bleach towelette or a 10% bleach solution. The bath water is contaminated and must be drained and the bath cleaned. See **CLEANING the BATH**.

## **CLEANING the BATH**

For your protection use gloves when working with any blood products. Turn the unit off. Connect the drain tubing to the DRAIN VALVE. Place the end of the tubing in a sink or drain. Open the valve by turning the lever clockwise (to vertical). Most of the water will drain out.

The bath is now light and easy to lift. Remove the CORRAL and take it to your sink for cleaning. Lift the BATH so that the PIVOTS lift off the notches and place the bath in front of the unit.

Disconnect the umbilical cord connecting to the chassis on the back of the BATH, by squeezing the 2 tabs on the connector. Take the BATH to your sink for easy cleaning. Wipe out the bath with a bleach towelette or a 10% bleach solution. **DO NOT USE CONCENTRATED BLEACH**. Rinse off the bleach with water.

Reassemble the unit. See Setting-Up.



## MODES

**STANDBY MODE.** Just turn the unit ON. The unit recirculates the water in the BATH, The unit heats up and maintains 37.0°C in the BATH.

**THAWING MODE.** The unit continues recirculating tempered water through the BATH and rocks the BATH to provide mixing of the plasma inside the plasma bags. A count-down timer is started to display the time-to-completion of thawing. START initiates thawing. Timing out or pushing STOP stops thawing.

**DIAGNOSTIC MODE.** Is for technician access. Hold MINUS as you turn the unit ON.

1. To restore the unit to initial factory settings, press ENTER while still holding MINUS. The unit displays “UNIT RESET”. Turn the unit off. You have to re-calibrate the temperature after resetting the unit.
2. “PUMP TEST” is a diagnostic tool to check if each actuator turns on. It is checked only when a pump does not operate. Release MINUS then push ENTER to verify that you are a technician. The display shows “PUMP TEST”. MINUS turns on Pump 1, ENTER turns the rocking motor. Push PLUS to go to next function.
3. ALARM TEST (OVERTEMP). Push ENTER, the heater will heat continuously and the pump will turn on. When the temperature reaches 1.0C above the target temperature the alarm will sound. Turn Off the unit. If alarm does not sound, contact CytoTherm. Alarm test should be performed every 3 months as part of unit maintenance.

**PROGRAM MODE.** Allows you to:

1. Program the thawing time.
2. Calibrate the temperature.
3. Set the target thawing temperature. The Alarm temperature is 1.0C above the target temperature.
4. Select the signal when thawing is done (continuous or pulsed).

Enter PROGRAM MODE by holding ENTER while turning the unit ON. Follow the displayed instructions to program. Pushing PLUS advances the menu to the next parameter.

**Programming the Thawing Time.** When the thawing time is displayed, press MINUS because you want to change the time. Use PLUS or MINUS to set the desired new thawing time, press ENTER to program in the new time. Turn the unit off.

**Calibrating Temperature.** Turn the unit on and let it heat up to 37.0°C. Check the displayed temperature with your accurate thermometer. Hold or hang your thermometer so the end is in the water in the bath. If the displayed temperature needs to be changed, turn the unit off. Enter PROGRAMMING MODE by holding ENTER as you turn the unit on. When the thawing time is displayed push PLUS until the display shows “CALIBRATE TEMPERATURE”. Push MINUS because you want to change the displayed temperature. Use PLUS or MINUS to make the displayed temperature agree with your thermometer. Push ENTER to record the calibration. Turn the unit off. If the unit can not be calibrated, or if the calibrated temperature is not stable, have a technician check the unit. See TECHNICIAN FUNCTIONS.

**SWITCH FUNCTIONS** There are 6 switches on the front panel:

**START.** Starts function.

**STOP.** Stops function.

**ENTER.** Records parameter changes.

**PLUS.** Steps through parameters and increases value of parameter.

**MINUS.** Allows change in parameter and decreases value of parameter.

**Sketch of FIN logo.** Not currently used. Future expansion.

## **TROUBLESHOOTING**

English: *Unit should be opened by qualified technicians only.*

French: *Ne puet être ouvert que un techicien autorize.*

---

Unit is "dead"	Verify that you are plugged into a live, grounded outlet.  Have qualified technician check if fuse is blown or connectors are loose. There are three fuses (see wiring diagram) in the unit. Fuse-1 & Fuse-2 are located on the circuit board.. 8Amp for 120Vac models and 5Amp for 240 Vac models. Fuse-3 is a ¾ Amp slow blow inline fuse on the transformer 12 Vac line.
Computer does not boot when turned on. Does not display readable messages.	Unit is not responding, but the display is backlit. Backlit display indicates that the unit has power. Turn unit off for at least 10 seconds and turn unit back on. If this does not solve problem, replace the computer (program module part# C4T-PM).
Display says “low water” but there is water.	The unit is not sensing that water is present. a. Make sure you are using tap water or adding salt to deionized water to make it conductive.  b. The level sensor (screw inside the BATH on the right side) is dirty. Scrape it and then clean with alcohol.
Unit does not heat but "heating" is displayed	Was the unit filled with water over 40C.? If yes then cool the water to 20C to reset the safety thermostat.  Check the Safety thermostat (#C-TH) and the heaters (#14-77) for continuity.
Temperature calibration does not “hold”, it changes .	Replace temperature sensor (#CT4-TS).
Temperature calibration is out of range.	Have technician check the voltage at TP1 (see wiring diagram) , it should be 0.395 +/- .001 Vdc. If TP1 was correct, replace the temperature sensor (#CT4-TS).  If TP1 was not correct, restore the unit to initial factory settings (see <b>DIAGNOSTICS</b> ) do full calibration. See Technician Functions > Full Calibration.
Pump does not circulate. No hum.	No power to pump or pump winding open. Check the umbilical connector. Check the pump (#14-PM). <b>DO NOT DISASSEMBLE PUMP.</b>
Pump does not circulate. Makes humming noise.	Blow air through pump outlet tubing to clear small obstruction. Check pump (#14-PM). <b>DO NOT DISASSEMBLE.</b> Any evidence of leaking on motor side means pump must be replaced.
Waterbath not rocking.	Check if cam is loose on motor. Check the rocking motor (#C-RM).

---

## **MESSAGES, Troubleshooting**

**COLD** indicates that the water temperature is less than 20.0C. As soon as the temperature rises above 20C, it will display the true temperature.

**TOO HOT** is an audible and displayed alarm condition that indicates that the bath temperature is 1.0C higher than the set temperature. If the operator pours hot water into the bath he/she will trigger this alarm.

This should never happen in normal operation. If it does, contact CytoTherm.

**LOW WATER** First make sure that a pinch ( 0.01 gr) of salt was added if deionized water was used. Pour water into the BATH to the correct level (see SETTING UP).

## **MAINTENANCE**

Daily: Wipe off the unit.

Once every two weeks:

### **Clean the BATH**

1. Remove the CORRAL(S) take them to the sink, clean under running water and wipe with bleach towelettes or a 10% bleach solution.
2. Drain the bath by attaching the provided tubing to the DRAIN valve and turning the valve handle clockwise to vertical. Drain as much water as possible through the drain valve. Lift the BATH and place it on the table with the PIVOTS in front of the ARMS. Disconnect the umbilical connector. Carry the bath to the sink and pour out the remaining water in the BATH.
3. Wipe the BATH with bleach towelettes or a 10% bleach solution. Use only water and bleach towelettes or a 10% bleach solutions for cleaning. **DO NOT USE CONCENTRATED BLEACH.** Use alcohol for removing oil or grease. **DO NOT IMMERSE THE WHOLE BATH. WIPE THE PUMP SCREEN FROM THE OUTSIDE ONLY. DO NOT REMOVE THE SCREWS.** Rinse off the bleach with water.
4. Close the DRAIN valve. Fill the bath with water. If you use deionized or distilled water add a little pinch ( about 0.01 gr.) of table salt. Add Algacide Part #ALG240 (1.0 ml. per 4 liter of water. Available in contiguous USA only) to the water. Any other bath clearing agent can also be used.
5. Mount the CORALL(S)

Every 3 Months:

**Temperature Calibration.** Run temperature calibration at least every 3 months or more often if your institution procedures or regulations require. See PROGRAM MODE > TEMPERATURE CALIBRATION.

**Overtemperature Alarm Test.** Have a technician run the ALARM TEST. See DIAGNOSTIC MODE > ALARM TEST

## PARTS LIST CT-4T

14-MP	Pump, Magnetic	\$198.-	DP-SW	Switch, 2-pole	\$ 20.
14-77	Heater (2 needed)	72.-	C-TH	Safety Thermostat	39.-
CT4-PC	Printed Circuit Board	400.-	C4-DISP	Display	80.-
C4T-BTH	Bath Section	700.-	C4-UMB	Wiring Harness	120.-
C-RM	Rocking Motor	160.-	C4T-PM	Program Module	100.-
C4-TS	Temperature Sensor	80.-	C4T-CLM	Clamp ( bag to cor.)	12.-
C4T-LID	Lid	200.-	C4T-CORS	Corral ( 6 plasma units)	400.-
C4-TR	Transformer 120V	60.	ALG240	Algaecide. USA only	66.-
C4-TR2	Transformer 240V	85.	CDR-VLV	Valve	54.-

Always specify model and serial number when ordering. Prices subject to change.

Oct 07

### SOURCES for SUPPLIES

BAGS overwrap 15 cm. wide by 30 cm. (6" x 12") long are available from US Plastics 1390 Neubrecht Rd. Lima OH 45801 Tel. 800 537-9724. Part #47352.

## TECHNICIAN FUNCTIONS

### FULL CALIBRATION

Adjust the 10-turn potentiometer so that the voltage between TP1 and Ground (Earth) is .395 V (see wiring diagram for locations). Actual temperature calibration is then set in Programming Mode (see PROGRAMMING MODE).

The trimmer near the BODY connector adjusts the display contrast.

## **SAFETY FEATURES**

### **WATER LEVEL SENSOR**

The unit will display **LOW WATER** and beep if there is not enough water to cover the level sensor inside the bath, a screw located 3/4" above the temperature sensor. The heat will also turn off. The water must be conductive in order for the level sensor to work. Use tap water or add a pinch (0.01 gr.) of salt if you are using de-ionized or distilled water.

### **OVER TEMPERATURE**

The unit will display **TOO HOT** and emit double-beeps if the temperature reaches 1.0°C above the thawing temperature. It will turn the heaters off.

### **SAFETY THERMOSTAT**

An independent safety thermostat will turn heaters off if the temperature goes above 45 °C. It has to be cooled to 20 C to reset.

### **FUSING**

The main fuses (Fuse-1 & Fuse-2) are located on the Printed Circuit Board and are 8Amp for 120Vac and 5Amp for 240Vac. Correct the cause of the blown fuse.

The transformer has a 3/4 Amp slow blow fuse (Fuse-3) on the wires of the 12 Vac winding used to generate the 5 Vdc supply.

### **ISOLATION**

The circuitry is isolated from the power lines by a transformer and from the heaters by an opto-coupled solid state relay.

## **ACCESSORIES**

Each **CORRAL** holds up to 6 units of **PLASMA**. One **CORRAL (C4T-CORS)** is included with the unit. If you wish to process up to 12 units at a time, you will need another **CORRAL (#C4T-CORS)**.

### **Revisions**

23 Apr 08 Every two weeks clean the bath.  
31 Oct 07 Ver. J No resistance test in maintenance. Parts prices  
8 Aug 07 Ver H No pricing.  
29 Mar 07 Ver. G Offer Algaecide  
1 Mar 07. Ver. F Do not use bleach.  
12 Dec 06. Ver. E Do not use concentrated bleach.  
20 Aug 06 add resistance test.  
25 June 06. ver E. Clarify  
18 Apr 05. ver D. Rack on shelf

Rev 25 June 06 Fuse Table & TP1  
 Rev 5 June 04 add 3/4A slow blow fuse  
 to 12 Vac Xform lead. See D 467.

Fuse	Amps	Vac	Type
1 & 2	8	120	Fast
1 & 2	5	240	Fast
3	3/4	12	Slow Blow

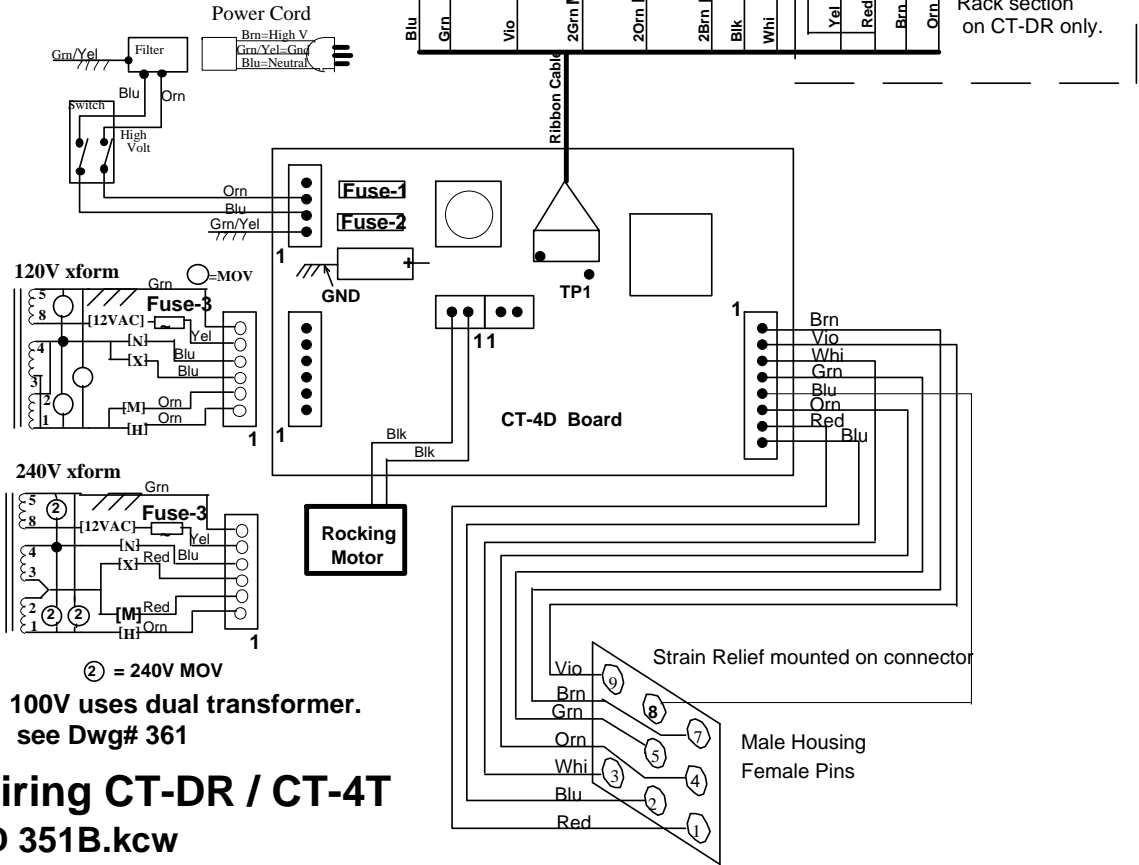

② = 240V MOV  
 100V uses dual transformer.  
 see Dwg# 361

## Wiring CT-DR / CT-4T D 351B.kcw

File \Draw#\D#351.kcw Home  
 30 Nov 2000  
 1 Jul 02. 8A Fuses for 120/100

Rev B. 4 Jan 04

1. Add separate Neutral wire from Bath Conn# 5 to 9-pin conn #8. Wire separate neutral wires to heaters & pump.
2. Spade connectors on heaters.
3. CT-DR & 4T on one drwg.

### 100V units

4. Move heater wires to 1/4" spade connectors from BATH connector.
5. Remove SWITCH conn. & solder wires directly to board.

Ground is Green with Yellow stripe



## Bath Section

120/100V wired as shown  
 240V the 2 heaters are in ser

