

CytoTherm

110 Sewell Ave. Trenton NJ 08610 USA
Tel 800 747-9699 or 609 396-1456 Fax 609 396-9395
Email serve@cytotherm.com Web www.cytotherm.com

CytoTherm-4S

Owners Manual

**COMPACT
PLASMA THAWING
WATER BATH
with Sliding Agitation**

Model **CT-4S**
Version 4.08 and higher.

Warranty

Each CytoTherm product is produced under rigid quality control standards. This unit is fully warranted for a period of one year from the date of purchase. Call (609) 396-1456 or (800) 747-9699 for help. If necessary send unit to:



CytoTherm 110 Sewell Avenue Trenton, NJ 08610 Fax (609) 396-9395

Please mail in your warranty card.

Please record the following: Serial No. _____ Date of Purchase _____

TABLE OF CONTENTS

\\DrawRec\Draw\Instructions\CT4SinsH.doc 30 Oct 07

1	Specifications	5	Troubleshooting
2	Description	6	Maintenance
2	Setting-up	6	Parts List
3	Operation	7	Technician Functions
3	Leaky Plasma Bag	7	Safety Features
3	Cleaning the Bath	8	Wiring Diagram
4	Modes of operation, Programming		

SPECIFICATIONS: Thawing temperature adjustable 25°C to 40°C. Preset to 37.0°C. Overtemp alarm 1.0°C over thawing temperature. 45°C safety thermostat. Accuracy 0.1°C. Easy to do, digital temperature calibration. Power 770 Watt, Available in 120 Volt or 230 Volts, 50 or 60 Hz. (must be grounded).

DESCRIPTION

The CytoTherm-4S (CT-4S) is laboratory instrument that uses a recirculating water temperature bath and a sliding action to agitate the plasma. The bags are pushed against bars to stir the plasma inside the bags and speed up the thawing time.

The CT-4S comes with a RACK that will thaw 1 to 4 plasma bags (up to 600 ml) at a time. The operator never comes in contact with the water in the BATH when handling the plasma. The RACK keeps the entry ports of flat-frozen units out of the water so an overwrap bag is not necessary. Folded frozen plasma units require an overwrap bag to protect the entry ports of the plasma bag. Both types of freeze methods can be thawed together.

A large digital display indicates the temperature and counts down the thawing time. The CT-4S comes with an evaporation cover.

SETTING-UP

The unit comes packed in 1 box. Make sure you have received the following:

..... Water Bath Link bar
..... Rack with 4 bag clamps Drain Tubing
..... Evaporation Cover Power Cord
..... Instruction Book Overwrap bags
..... Video or DVD Algaecide USA only

Fill the BATH with tap water to the bottom of the shelf that supports the RACK (12 liters). If your water contains a lot of lime, use distilled or de-ionized water, add a pinch (0.01 gr.) of salt to make the water conductive so the level sensors will work. Do NOT use saline solution. Add Algaecide Part #ALG240 (3.0 ml. Available USA only) to the water. Any other bath clearing agent can also be used.

Connect the power cord to the BATH and then plug the power cord into a properly grounded electrical outlet.

Turn the POWER switch ON. The pump will start recirculating the water and the display will indicate the temperature. The unit will heat up to 37.0°C. (The thawing temperature is adjustable. See Programming in MODES). The display will show “HEAT ON” when the unit is heating.

OPERATION

Wait for the water to heat up to 37.0°C.

For your protection, use gloves when working with any blood products.

Flat-frozen plasma units can be thawed without an overwrap bag. Hold a bag of flat-frozen plasma (bare or overwrapped) with the tubes up. Slip the CLAMP (plastic piece with a stainless spring attached) over the top of the bag and line up the 3 grooves in the CLAMP with the tubes of the plasma bag.

Place the bottom of the plasma bag into the water, between the rods of the RACK. Pull the stainless spring of the CLAMP over the screw head in the RACK. The spring should pull the plastic bar and plasma bag snugly against the corral. The spring tension can be adjusted by bending the stainless steel spring. If the stainless steel spring breaks, the clamp must be replaced (Part # C4S-CLM).

Folded frozen plasma must be overwrapped. Load it the same way. The CLAMP will hold the plasma unit by the overwrap bag.

Overwrap bags 15 cm. wide by 30 cm. (6" x 12") long are available from Rutan Supply 39 Siding Pl. Mahwah, NJ 07430 Tel. 800 872-1474.

The LINK bar connects the RACK to the rack motor. Place the protruding rod of the LINK into the hole on top of the RACK. The hole in the LINK fits over the protruding rod on the rack motor cam.

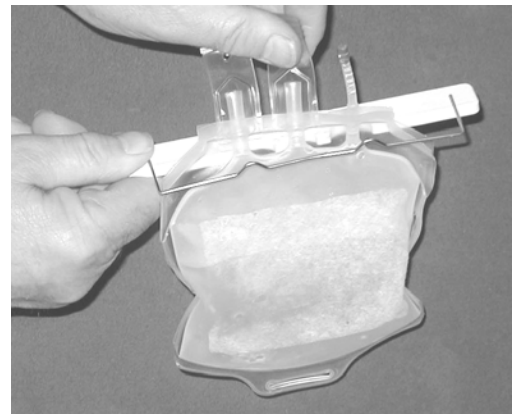

Push START to begin thawing for the programmed time. The RACK will slide back and forth forcing the plasma bags against the rods of the RACK and massaging the plasma. Use PLUS or MINUS to increase or decrease the thawing time. When the time is finished, the buzzer will call the operator back.

The STOP switch ends the thawing. If more thawing time is needed, hold PLUS while pushing START and the unit will thaw for another 3 minutes.

Remove the LINK and cover the bath with the evaporation cover when plasma is not being thawed. Turn the POWER switch off if the CT-4S will not be used for a while. The BATH requires 25 minutes to raise the temperature from room temperature to 37° C, ready for thawing plasma.

LEAKY PLASMA BAG

If a Plasma bag leaks, turn the unit off and discard the leaking bag. The remaining bags are not contaminated, because the ports are always kept out of the water. The bath water is contaminated and must be drained and the bath cleaned. See CLEANING the BATH.

CLEANING the BATH

For your protection use gloves when working with any blood products. Turn the unit off. Connect the drain tubing to the DRAIN VALVE. Place the end of the tubing in a sink or drain. Open the valve by turning the lever clockwise. Most of the water will drain out.

Remove the LINK and the RACK and rinse them out under running water in the sink. Wipe them down with Bleach Towelettes or a 10% bleach solution. DO NOT USE CONCENTRATED BLEACH

The CT-4S is now light and easy to lift. Remove the RACK and take it to your sink for cleaning. Take the CT-4S to your sink for easy cleaning and disinfect it with bleach towelettes or a 10% bleach solution. Rinse off all the bleach.

Reassemble the unit. See SETTING UP.

MODES

STANDBY MODE. Just turn the unit ON. The unit recirculates the water in the BATH, The unit heats up and maintains 37.0°C in the BATH.

THAWING MODE. The unit continues recirculating tempered water through the BATH and starts moving the RACK back and forth. The hanging plasma bags are pushed against rods in the RACK mixing the plasma in the bags. A count-down timer is started to display the time-to-completion of thawing. START initiates thawing. Timing out or pushing STOP stops thawing.

DIAGNOSTIC MODE. Is for technician access. Hold MINUS as you turn the unit ON.

1. To restore the unit to initial factory settings, press ENTER while still holding MINUS. The unit displays “UNIT RESET”. Turn the unit off. You have to re-calibrate the temperature after resetting the unit.
2. “PUMP TEST” is a diagnostic tool to check if each actuator turns on. It is checked only when a pump does not operate. Release MINUS then push ENTER to verify that you are a technician. The display shows “PUMP TEST”. MINUS turns on Pump 1, ENTER turns the cam to push the RACK back and forth. Push PLUS to go to next function.
3. **ALARM TEST (OVERTEMP).** Push ENTER, the heater will heat continuously and the pump will turn on. When the temperature reaches 1.0C above the target temperature the alarm will sound. Turn Off the unit. If alarm does not sound, contact CytoTherm. Alarm test should be performed every 3 months as part of unit maintenance.

PROGRAM MODE. Allows you to:

1. Program the thawing time.
2. Calibrate the temperature.
3. Set the target thawing temperature. The Alarm temperature is 1.0C above the target temperature.
4. Select the signal when thawing is done (continuous or pulsed).

Enter PROGRAM MODE by holding ENTER while turning the unit ON. Follow the displayed instructions to program. Pushing PLUS advances the menu to the next parameter.

Programming the Thawing Time. When the thawing time is displayed, press MINUS because you want to change the time. Use PLUS or MINUS to set the desired new thawing time, press ENTER to program in the new time. Turn the unit off.

Calibrating Temperature. Turn the unit on and let it heat up to 37.0°C. Check the displayed temperature with your accurate thermometer. Hold or hang your thermometer so the end is in the water in the bath. If the displayed temperature needs to be changed, turn the unit off. Enter PROGRAMMING MODE by holding ENTER as you turn the unit on. When the thawing time is displayed push PLUS until the display shows “CALIBRATE TEMPERATURE”. Push MINUS because you want to change the displayed temperature. Use PLUS or MINUS to make the displayed temperature agree with your thermometer. Push ENTER to record the calibration. Turn the unit off. If the unit can not be calibrated, or if the calibrated temperature is not stable, have a technician check the unit. See TECHNICIAN FUNCTIONS.

SWITCH FUNCTIONS There are 6 switches on the front panel:

START. Starts function.

STOP. Stops function.

ENTER. Records parameter changes.

PLUS. Steps through parameters and increases value of parameter.

MINUS. Allows change in parameter and decreases value of parameter.

Sketch of FIN logo. Not currently used. Future expansion.

TROUBLESHOOTING

English: *Unit should be opened by qualified technicians only.*

French: *Ne puet être ouvert que un techicien autorize.*

Unit is "dead"	Verify that you are plugged into a live, grounded outlet. Have qualified technician check if fuse is blown or connectors are loose. There are three fuses (see wiring diagram) in the unit. Fuse-1 & Fuse-2 are located on the circuit board. 8Amp for 120Vac models and 5Amp for 240 Vac models. Fuse-3 is a ¼ Amp slow blow inline fuse on the transformer 12 Vac line.
Computer does not boot when turned on. Does not display readable messages.	Unit is not responding, but the display is backlit. Backlit display indicates that the unit has power. Turn unit off for at least 10 seconds and turn unit back on. If this does not solve problem, replace the computer (program module part# C4S-PM).
Display says "low water" but there is water.	The unit is not sensing that water is present. a. Make sure you are using tap water or adding salt to deionized water to make it conductive. b. The level sensor (screw inside the BATH on the right side) is dirty. Scrape it and then clean with alcohol.
Unit does not heat but "heating" is displayed	Was the unit filled with water over 40C.? If yes then cool the water to 20C to reset the safety thermostat. Check the Safety thermostat (#C-TH) and the heaters (#14-77) for continuity.
Temperature calibration does not "hold", it changes .	Replace temperature sensor (#CT4-TS).
Temperature calibration is out of range.	Have technician check the voltage at TP1 (see wiring diagram) , it should be 0.395 +/- .001 Vdc. If TP1 was correct, replace the temperature sensor (#CT4-TS). If TP1 was not correct, restore the unit to initial factory settings (see DIAGNOSTICS) do full calibration. See Technician Functions > Full Calibration.
Pump does not circulate. No hum.	No power to pump or pump winding open. Check the pump (#14-PM). DO NOT DISASSEMBLE PUMP.
Pump does not circulate. Makes humming noise.	Blow air through pump outlet tubing to clear small obstruction. Check pump (#14-PM). DO NOT DISASSEMBLE. Any evidence of leaking on motor side means pump must be replaced.
RACK not moving back and forth	Check if cam is loose on motor. Check the rack motor (#C4S-RKM).

MESSAGES, Troubleshooting

COLD indicates that the water temperature is less than 20.0C. As soon as the temperature rises above 20C, it will display the true temperature.

TOO HOT is an audible and displayed alarm condition that indicates that the bath temperature is 1.0C higher than the set temperature. If the operator pours hot water into the bath he/she will trigger this alarm. This should never happen in normal operation. If it does, contact CytoTherm.

LOW WATER First make sure that a pinch (0.01 gr) of salt was added if deionized water was used. Pour water into the BATH to the correct level (see SETTING UP).

MAINTENANCE

Daily: Wipe off the unit.

Once every two weeks:

Clean the BATH

1. Remove the RACK and take it to the sink, clean under running water and wipe with bleach towelettes or a 10% bleach solution. Rinse off the rack in running water.
2. Drain the bath by attaching the provided tubing to the DRAIN valve and turning the valve handle clockwise to vertical. Tilt the bath to drain as much water as possible through the drain valve.
3. Wipe the BATH and RACK with bleach towelettes or a 10% bleach solution. Use only water and bleach towelettes or a 10% bleach solutions for cleaning. Use alcohol for removing oil or grease. **DO NOT IMMERSE THE WHOLE BATH. WIPE THE PUMP SCREEN FROM THE OUTSIDE ONLY. DO NOT REMOVE THE SCREWS.** Rinse out the bleach with water.
4. Close the DRAIN valve. Fill the bath with water. If you use deionized or distilled water add a little pinch (about 0.01 gr.) of table salt. . Add Algaecide Part #ALG240 (1.0 ml. per 4 liter of water. Available USA only) to the water. Any other bath clearing agent can also be used.
5. Mount the RACK

Every 3 Months:

Temperature Calibration. Run temperature calibration at least every 3 months or more often if your institution procedures or regulations require. See PROGRAM MODE > TEMPERATURE CALIBRATION.

Overtemperature Alarm Test. Have a technician run the ALARM TEST. See DIAGNOSTIC MODE > ALARM TEST

PARTS LIST CT-4S

14-MP	Magnetic pump	\$198.-	DP-SW	Switch, 2-pole	\$ 20.
14-77	Heater (2 needed)	72.-	C-TH	Safety Thermostat	39.-
CT4-PC	Printed Circuit Board	400.-	C4-DISP	Display	80.-
C4S-BTH	Bath Section	700.-	C4-TR	Transformer 120V	60.-
C4S-RKM	Rack Motor	90.-	C4-TR2	Transformer 240V	85.-
C4-TS	Temperature Sensor	80.-	C4S-CLM	Clamp (bag to rack)	12.-
C4S-EL	Evaporation Lid	75.-	C4S-RK	Rack (holds 4 bags)	300.-
C4S-LINK	Link Bar	30.-	CT4-VLV	Valve	54.-
ALG240	Algaecide. USA only	66.-	C4S-PM	Program Module	100.-

Always specify model and serial number when ordering. Prices subject to change Oct 07

SOURCES for SUPPLIES

BAGS overwrap 15 cm. wide by 30 cm. (6' x 12") long are available from US Plastics 1390 Neubrecht Rd. Lima OH 45801
Tel. 800 537-9724. Part #47352.

TECHNICIAN FUNCTIONS

FULL CALIBRATION

Adjust the 10-turn potentiometer so that the voltage between TP1 and Ground (Earth) is .395 V (see wiring diagram for locations). Actual temperature calibration is then set in Programming Mode (see PROGRAMMING MODE).

The trimmer near the BODY connector adjusts the display contrast.

SAFETY FEATURES

WATER LEVEL SENSOR

The unit will display LOW WATER and beep if there is not enough water to cover the level sensor inside the bath, a screw located 3/4" above the temperature sensor. The heat will also turn off. The water must be conductive in order for the level sensor to work. Use tap water or add a pinch (0.01 gr.) of salt if you are using de-ionized or distilled water.

OVER TEMPERATURE

The unit will display TOO HOT and emit double-beeps if the temperature reaches 1.0°C above the thawing temperature. It will turn the heaters off.

SAFETY THERMOSTAT

An independent safety thermostat will turn heaters off if the temperature goes above 45 °C. It has to be cooled to 20 C to reset.

FUSING

The main fuses (Fuse-1 & Fuse-2) are located on the Printed Circuit Board and are 8Amp for 120Vac and 5Amp for 240Vac units. Correct the cause of the blown fuse.

The transformer has a ¾ Amp slow blow fuse (Fuse-3) on the wires of the 12 Vac winding used to generate the 5 Vdc supply.

ISOLATION

The circuitry is isolated from the power lines by a transformer and from the heaters by an opto-coupled solid state relay.

Revisions:

- 7 Oct 10 Fill with water to bottom of shelf.
- 23 Apr 08 Every two weeks clean the bath.
- 30 Oct 07 Ver. H remove resistance test.
- 20 Aug 06 add resistance test.
- 25 June 06. Ver. D Clarify.
- 12 Dec 06. Still Ver. D. Do not use concentrated bleach.
- 1 Mar 07. Ver E. Do not use bleach.
- 29 Mar 07 Ver F. Offer Algicide #ALG240
- 8 Aug 07 Ver G. No pricing.

Rev 25 Jun 06 Fuse Table & TP1
 Rev 5 June 04 add 3/4A slow blow fuse
 to 12 Vac Xform lead. See D 467.

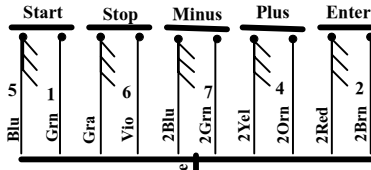

Fuse	Amps	Vac	Type
1&2	8	120	Fast
1&2	5	240	Fast
3	3/4	12	Slow Blow

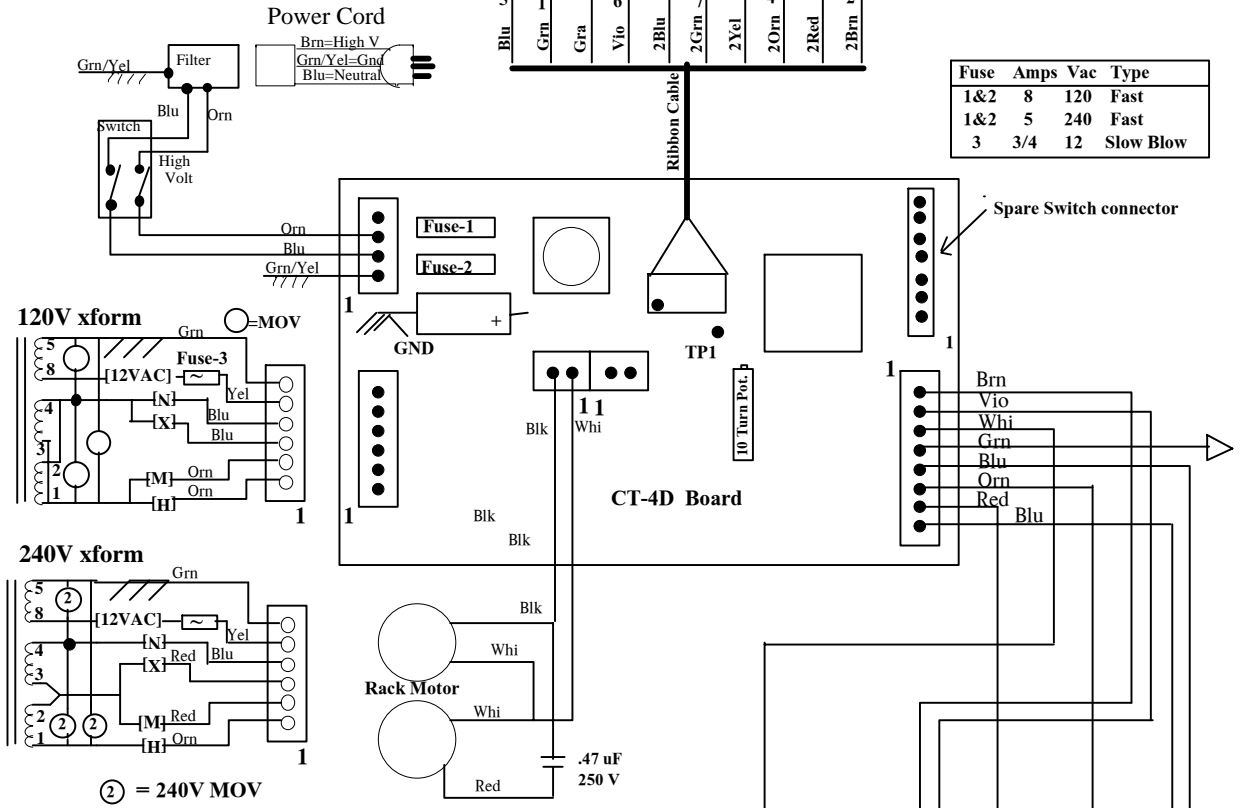

Wiring CT-4S

Dwg # 433

File WCT4S.kew Home

May 2002

Used in CT-4S Instruction Book \Draw#\CT4SinsX.doc

Ground is Green with Yellow stripe

120V wired as shown
 240V the 2 heaters are in series

Blu Both Blu wires are Neutral
 Blu